

ProVision

Magex produces
with quality system
certified by



A vending machine designed to celebrate the 10th anniversary of Magex patented dispensing system, a real automated shop.

Thanks to its 14 lanes per floor with a total of 2240 products in 112 different types, 224 in the ProVision Dual version, hosting up to 4480 products. Possibility to refrigerate.

MAGEX LOADING SYSTEM

Maximum adaptability to distribute any type of product, you can pair more than one lane in an automatic way to distribute products that are wider. The system also allows the insertion of interlocking partitions to separate products that are next to one another from the next. The system has a self-diagnosis system that checks the operating status of the lane before any disbursement of the product.

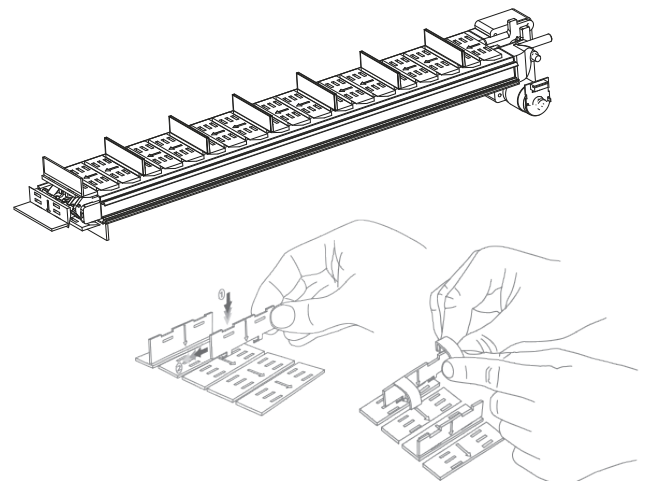

REAL TIME DATA SERVICE

Magex provides to all its customers a service for the management of the vending machines updated in real time, connected via web and accessible from laptops, mobile phones, etc.

This allows you to view real-time data of each sale, the stock status, the coins/ banknotes inserted or returned, automatic reboots and other functions. It also monitors the temperature inside the machine with graphics.



ProVision

Master

Slave

Console 22"



Width	1520 mm	1300 mm	+300mm
Depth	885 mm	885 mm	885 mm
Height	1995 mm	1995 mm	1995 mm
Weight (with 6 floors)	600 Kg	450 Kg	200 Kg
Maximum number of floors	8	8	
Selection supply of floors Min-Max	2 to 14	2 to 14	
Voltage supply	High luminosity LEDs (20 W)	High luminosity LEDs (20 W)	
Power consumption	240V/50Hz 110V/60Hz	240V/50Hz 110V/60Hz	240V/50Hz 110V/60Hz
Power consumption by cooling unit	420 W	420 W	+75 W
Climate class refrigeration unit	5	5	
Temperature control and cooling system	Electronic with alarm in real time	Electronic with alarm in real time	
Internal temperature	2°C	2°C	
Operating temperature of cooling unit	up to 40°C	up to 40°C	
Payment system compatibility	MDB/CCTALK		

TECHNICAL SPECIFICATIONS



- Distributor armored with double opening locks independent from the money holding area to the insertion of the money.
- The products displayed in the distributor are illuminated by high-efficiency LEDs.
- An elevator transports the selected product in the compartment for easy access.
- Restocking of products in the machine is facilitated by the extraction of the complete floors, from the front or back, via the sliding rails.
- Modular system, it can be expanded at any time with additional slave machines.
- Through an advanced Data Management, you have control over every single sale in real time via GPRS technology.

OPTIONALS

- Bill reader
- Bill validator with change
- Coins reader in tubes with change
- Coins reader with change multihopper
- Outdoor cover
- GSM data management
- Lexan protection
- LCD prices display
- Lift
- Fridge
- Variable weight managing system
- Camera kit

- Graphic customization
- RFID loyalty card system
- Age verification
- Motor-powered age verification
- Rear door for interior refilling
- Credit card and bancomat reader

STANDARD COLOURS

-  White
RAL 9016
-  Black
RAL 9005